

Type ULF

Ultra Low Flow Sensors

The Type ULF Ultra Low Flow Sensors are available in two flow ranges. They contain a transducer and a four blade paddle wheel rotor with a permanent magnet inside each blade. A square wave output signal is generated with frequency proportional to rate of rotor rotation and flow velocity. This pulse output is normally fed to a FlowX3 flow monitor/transmitter, blind transmitter, batch controller or adjustable flow switch. It can also be fed to other brand instruments or PLC's.

Two types of sensors are available, Hall Effect which requires a 5 to 24 VDC power supply and Reed Effect which have a volt-free contact. Reed Effect is required with the battery powered flow monitor. Hall Effect signals may be transmitted up to 300 meters (984 ft.) without the need for conditioning whereas Reed Effect signals may be transmitted up to 16 m (52.5 ft.) without conditioning.

	Polyoxymethylene (POM) Version	ECTFE Version
Sensor Body:	POM	ECTFE (Halar®)
Rotor:	POM	ECTFE (Halar®)
Shaft:	Corepoint®†	Sapphire
Bearings:	–	Sapphire
O-Ring:	Viton®	Viton® or Kalrez®
Connections:	Inline 1/4" BSP male threaded	
Flow Ranges:		
ULF01 Model:	1.5 to 100 l/h (0.0066 to 0.44 gpm)	
ULF03 Model:	6 to 250 l/h (0.0264 to 1.10 gpm)	

■ Features

- **Connects to the Full Range of FlowX3 Instruments**
All models of the Flow Monitor/Transmitters and Batch Controller may be connected remotely, either panel or wall mounted.

† Corepoint® is a steel alloy.

■ Connectable FlowX3 Instruments

Instrument Mounting	Sensor No.	Sensor Type	FlowX3 Instruments*
Panel or Wall	ULF.H	Hall	F9.01, F9.02, F9.03, F9.50, F9.51
Panel or Wall	ULF.R	Reed	F9.00, F9.20

* Power supply is normally fed from FlowX3 instruments.

Digiflow®
FLOW X3

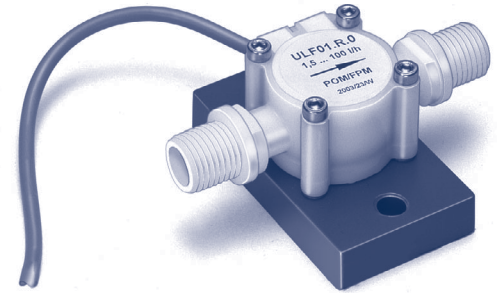

■ Wiring

ULF.H Sensor Connection to FlowX3 Instruments



ULF.H Sensor Connection to Other Brand Instruments

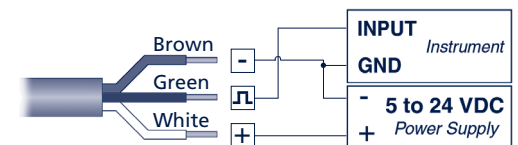

ULF.R Sensor Connection to FlowX3 and Other Brand Instruments



Type ULF

Ultra Low Flow Sensors



■ Technical – General

Output Signal:	Square wave (pulse)
Pulses per Litre:	See page 44
Electrical Class:	NEMA 4, 4X (IP65)
Accuracy:	< ± 2% of reading value after field calibration or ± 1.0% of full scale
Repeatability:	± 0.5% of full scale
Viscosity Range:	1 to 10 centistokes
Maximum % Solids:	Clean services only, no solids recommended
Working Temperature:	-10 to 80°C (14 to 176°F)
Working Pressure:	5 bar (70 psi) max. @ 22°C (72°F)
Cable:	22 AWG, 3 conductors

■ Technical – ULF.H (Hall Effect) Sensor

Supply Voltage*:	5 to 24 VDC regulated
Supply Current:	< 15 mA @ 24 VDC
Max. Cable Length:	Max. 300 m (984 ft.) recommended without signal conditioning

■ Technical – ULF.R (Reed Effect) Sensor

Output Type:	Volt free Reed contact
Max. Cable Length:	Max. 16 m (52.8 ft.) recommended without signal conditioning

* Supply voltage is normally fed from FlowX3 instruments.

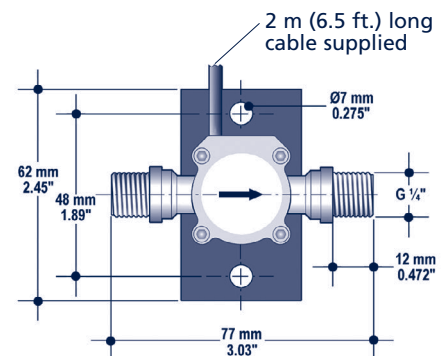
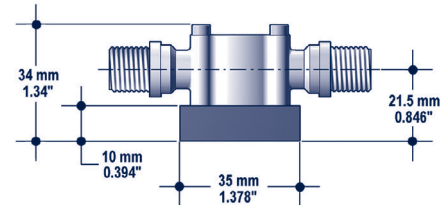

Connections:
1/4" BSP male thread

■ Installation Guidelines

- The sensor can be installed in any position, horizontally or vertically, although horizontal is preferred. A non horizontal installation may cause a greater error in the lower flow measurement range.
- Install the sensor with the arrow pointing in the flow direction.
- Maximize the distance between sensor and pump. Do not install the sensor immediately downstream of valves, elbows or any obstacles. 15 cm (6") of straight pipe is suggested before and after the sensor.

■ Item Numbers

Electrical Class	Materials		Flow Rate		Item No.	
	Body	O-Ring	l/hr	USGPM	Hall	Reed
NEMA 4, 4X (IP65)	POM	Viton®	1.5 – 100	0.0066 – 0.44	ULF01.H.0	ULF01.R.0
			6.0 – 250	0.0264 – 1.10	ULF03.H.0	ULF03.R.0
	ECTFE	Viton®	1.5 – 100	0.0066 – 0.44	ULF01.H.2	ULF01.R.2
			6.0 – 250	0.0264 – 1.10	ULF03.H.2	ULF03.R.2
		Kalrez®	1.5 – 100	0.0066 – 0.44	ULF01.H.3	ULF01.R.3
			6.0 – 250	0.0264 – 1.10	ULF03.H.3	ULF03.R.3