

# Neptune m100 ST

## Coriolis Mass Flowmeter

Refined Fuels  
**neptune**  
 / Industrial Liquids



**Flow Rate 5.0 to 500 kg/min (11 to 1100 lb/min)**

**Direct Mass, Density and Temperature Measurement • No Moving Parts  
 Patented Omega Flowtubes • Smooth-bore, Non-obtrusive Flow Path  
 Wide 100:1 Turndown • Lowest Pressure Drop**

The Neptune m100 ST mass flowmeter provides continuous direct measurement of mass, density, temperature, and percent solids over the flow range of 5.0 to 500 kg/min (11 to 1100 lbs/min).

Patented dual omega-shaped tubes provide outstanding sensitivity to Coriolis forces. Mass flow accuracy is +/- 0.10% with the NexGen SFT200 mass flow transmitters. The mass flow repeatability is +/- 0.10% and the density accuracy is +/- 0.001 g/cc over its operating range.

The transducer is more sensitive to Coriolis forces than conventional mass flowmeters, providing a greater mechanical gain. Fluid velocity requirements are much lower to produce a given signal. This results in a lower pressure drop and unequalled 100:1 turndown. Accuracy never has to be compromised to obtain an acceptable pressure drop.

The smooth-bore, non-obtrusive flow path is free from moving parts, seals, and bellows. The omega shape reduces stress on the tubes for improved durability.

# m100 ST Operating Specifications

<b>METERING ELEMENT</b>	Meter model number: M100 XXXXXXXXXXXX (refer to Ordering Information, page 3)
<b>Connections:</b> Connection type	ANSI: 1", 1-1/2", 2"; 150#, 300#, 600# RF Industrial Tri-Clamp®: 2"
<b>Meter:</b> Tube material Tube shape Nominal tube bore Housing Mass accuracy Mass repeatability Mass zero stability Turndown ratio Density range Density accuracy Density repeatability Temperature measurement Temperature accuracy	316L SST Omega 25.4 mm (1.0") 304L SST ±0.10% of rate ± zero stability (with NexGen SFT200) ±0.10% of rate ±0.246 kg/min (0.0543 lb/min) (with NexGen SFT200) 100:1 0.4 to 3.0 g/cc (with NexGen SFT200) ±0.001 g/cc ±0.0005 g/cc 100 ohm platinum resistance sensor 0.56°C (±1°F)
<b>Fluid:</b> Flow rate Max. temperature Min. temperature Max. operating pressure	5.0 to 500 kg/min (11 to 1100 lb/min) 204°C (400°F) -45°C (-50°F) 83 bar (1200 psi); limited by flange rating
<b>ASSOCIATED INSTRUMENT</b>	
Power/Data cables  Max. length of signal cables Electrical connections Manufacturer Instrument model number	Power: 2 conductor shielded twisted pair Pulse Output: 2 conductor shielded twisted pair 485 Output : 2 Conductor 300 m (1000 ft.) Screw terminal Itron, Inc. NexGen SFT200

## Electronics

NexGen® SFT200 Mass Flow Transmitter (Complete information is available in TS-621.)

## Ordering Information

MODEL NUMBER		DESCRIPTION
M100 ST	XXXXXXXXXX	
	7	<b>Type</b> Transducer 1" SST <sup>1</sup>
	832 833 842 852 853 856	<b>Flange</b> 1" 150lb. ANSI RF SST 1" 300lb. ANSI RF SST 1-1/2" 150lb. ANSI RF SST 2" 150lb. ANSI RF SST 2" 300lb. ANSI RF SST 2" SST Industrial Tri Clamp <sup>2</sup>
	0	<b>Approvals</b> General Purpose
	0	<b>W &amp; M</b> None
	000	<b>Cable</b> No Cable
	R1	<b>Electronics</b> For Use With NexGen SFT200

<sup>1</sup>Note: Wetted materials and connection materials must be the same.

<sup>2</sup>Note: The 2" industrial connection is available in 316L SS wetted material only.

## Pressure Drop Versus Flow Rate

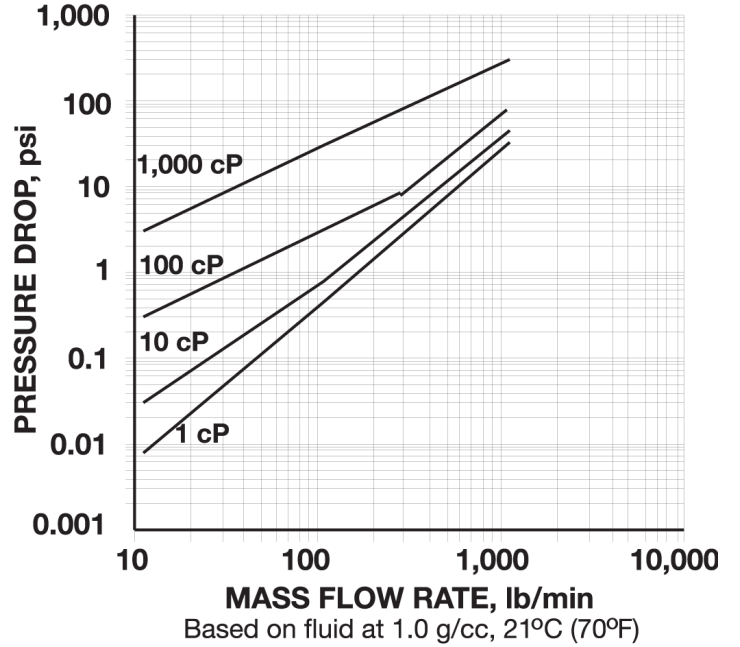
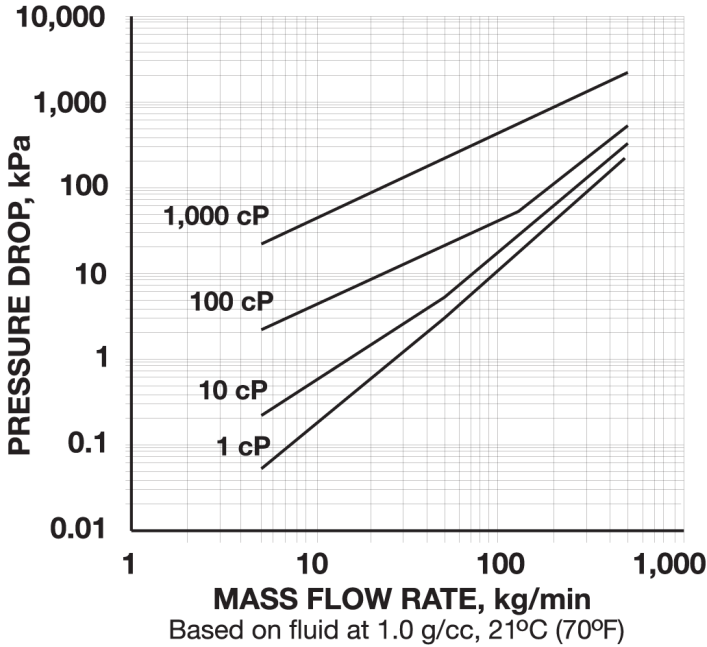

### Determining Pressure Drop

1. Flow rate vs. pressure drop varies with viscosity. To approximate m100ST pressure drop for fluids with viscosity approximating that of water, locate the point on the 1-cP curve corresponding with your desired flow rate.
2. From that point, locate the nearest horizontal line and follow it to the vertical scale on the left, which indicates pressure drop for the flow rate you selected.
3. Divide the pressure drop indicated on the graph by the specific gravity (S) of the process fluid:

$$\Delta P_{\text{actual}} = \Delta P_{\text{plotted}} / \text{Sp. Gr.}$$

### Calculating Actual Accuracy

Use the following formula to calculate  $\dot{m}^{\circ}$  accuracy for your selected flow rate:

$$\% \text{ accuracy, } B1_{\text{actual}} = \{ [(0.0010 m) + S_0] / m \} \times 100\%$$

where:

m = mass flow rate, kg/min or lb/min

S<sub>0</sub> = mass zero stability, kg/min or lb/min for the m100 flowmeter

Note: Itron offers a free sizing program CD to assist you in your selection.

## Dimensions

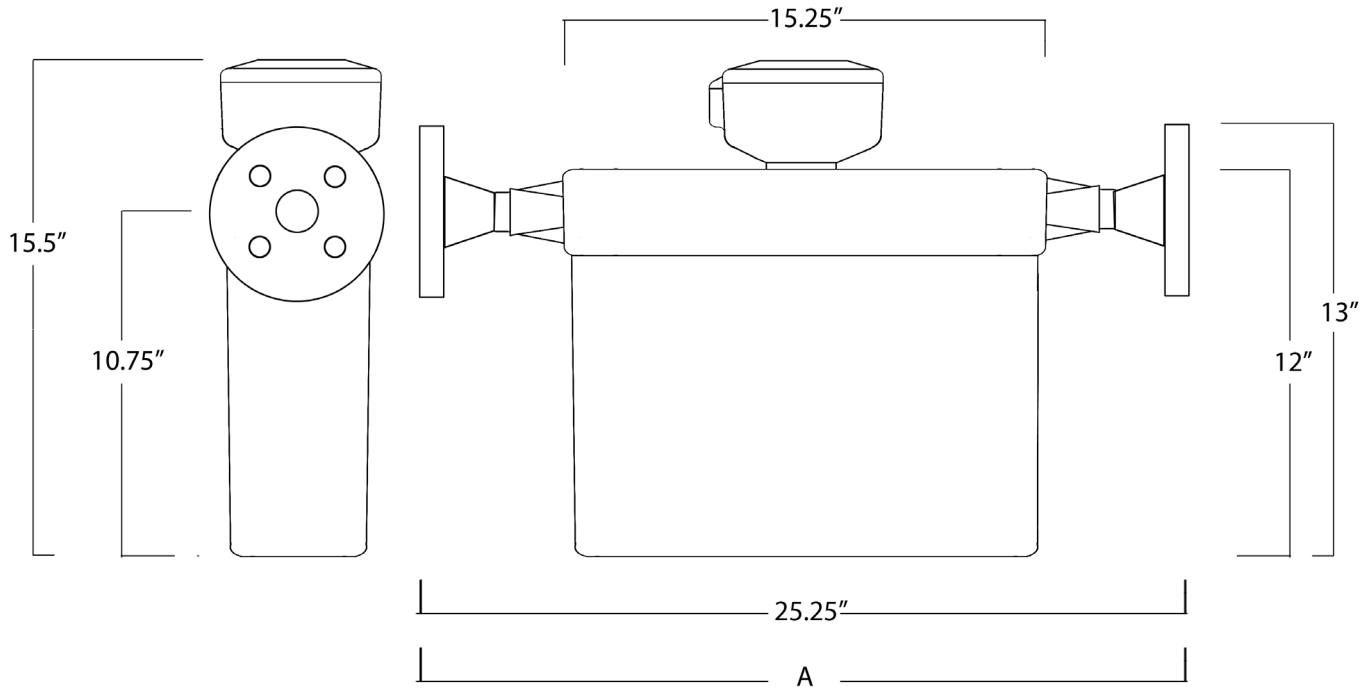

*Shown with 1" 300# weld-neck flanges and NexGen SFT200 Mass Flow Transmitter*

Length With Other Available Flanges	
Flange	Dimension A
1" 150# ANSI RF	533mm (21 in)
1" 300# ANSI RF	551mm (21.7in)
1-1/2" 150# ANSI RF	542mm (21.32in)
1-1/2" 300# ANSI RF	559mm (22.02in)
2" 150# ANSI RF	549mm (21.62in)
2" 300# ANSI RF	564mm (22.22in)

## Weight (as shown)

**m100 ST:** 23.3 lbs

**NexGen SFT200:** 3.4 lbs

**2 - 1" 300# weld-neck flanges:** 7.50 lbs

**Total weight:** 34.2 lbs



1310 Emerald Road  
Greenwood, SC 29646  
USA  
Phone: 1.800.833.3357  
Fax: 1.864.223.0341

07/11

